

6

5

4

3

2

1

D

D

C

C

B

B

A

A

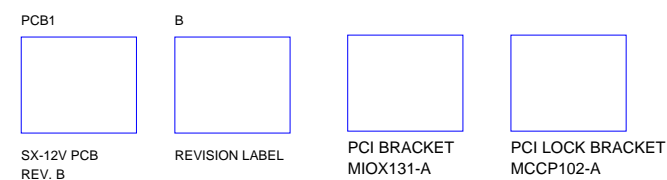
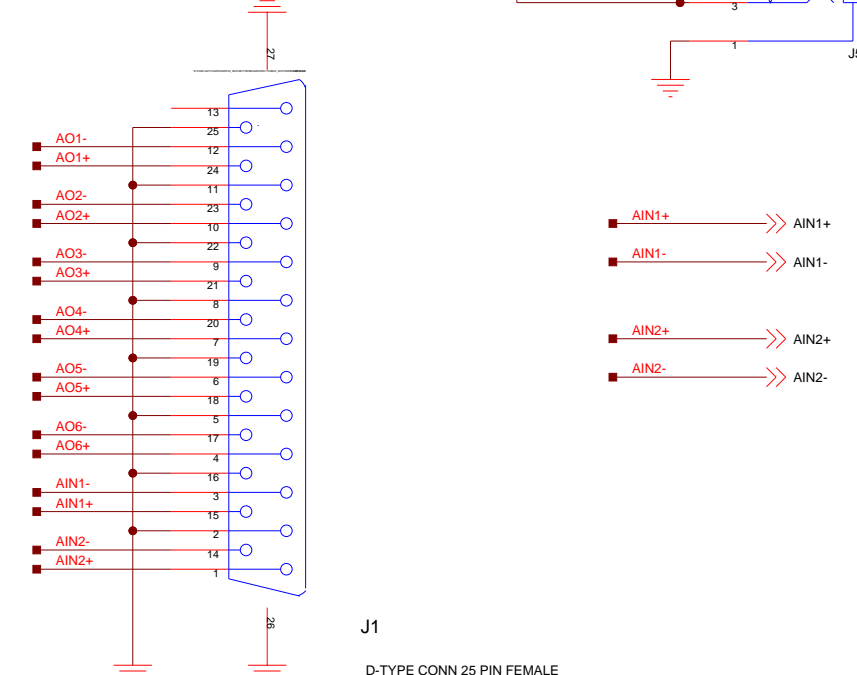
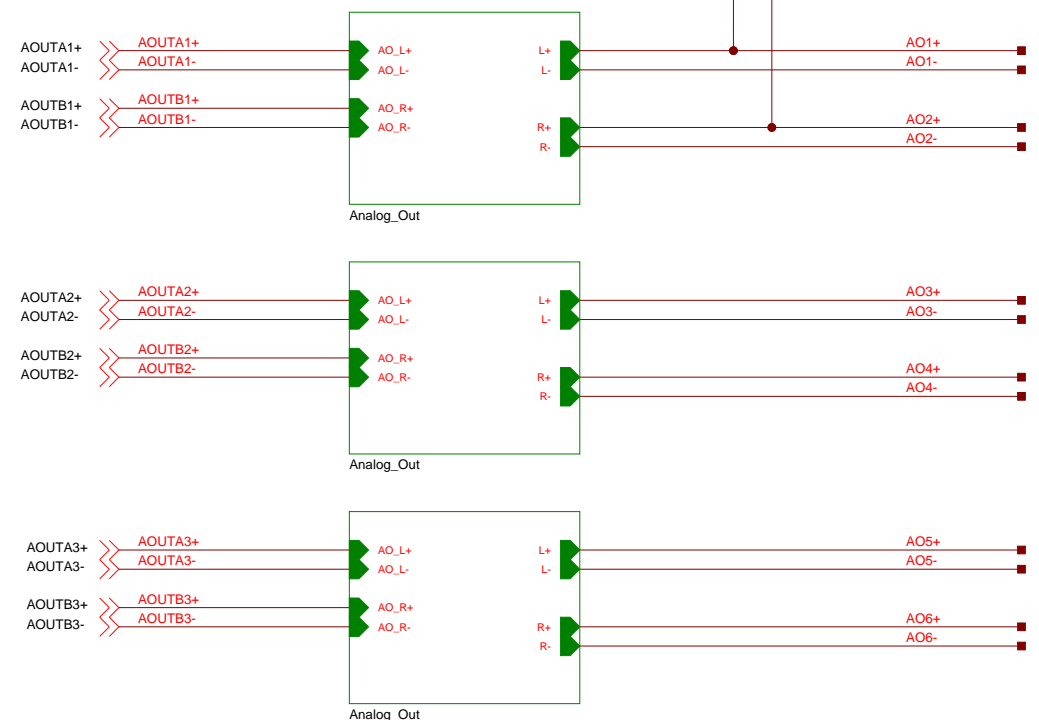
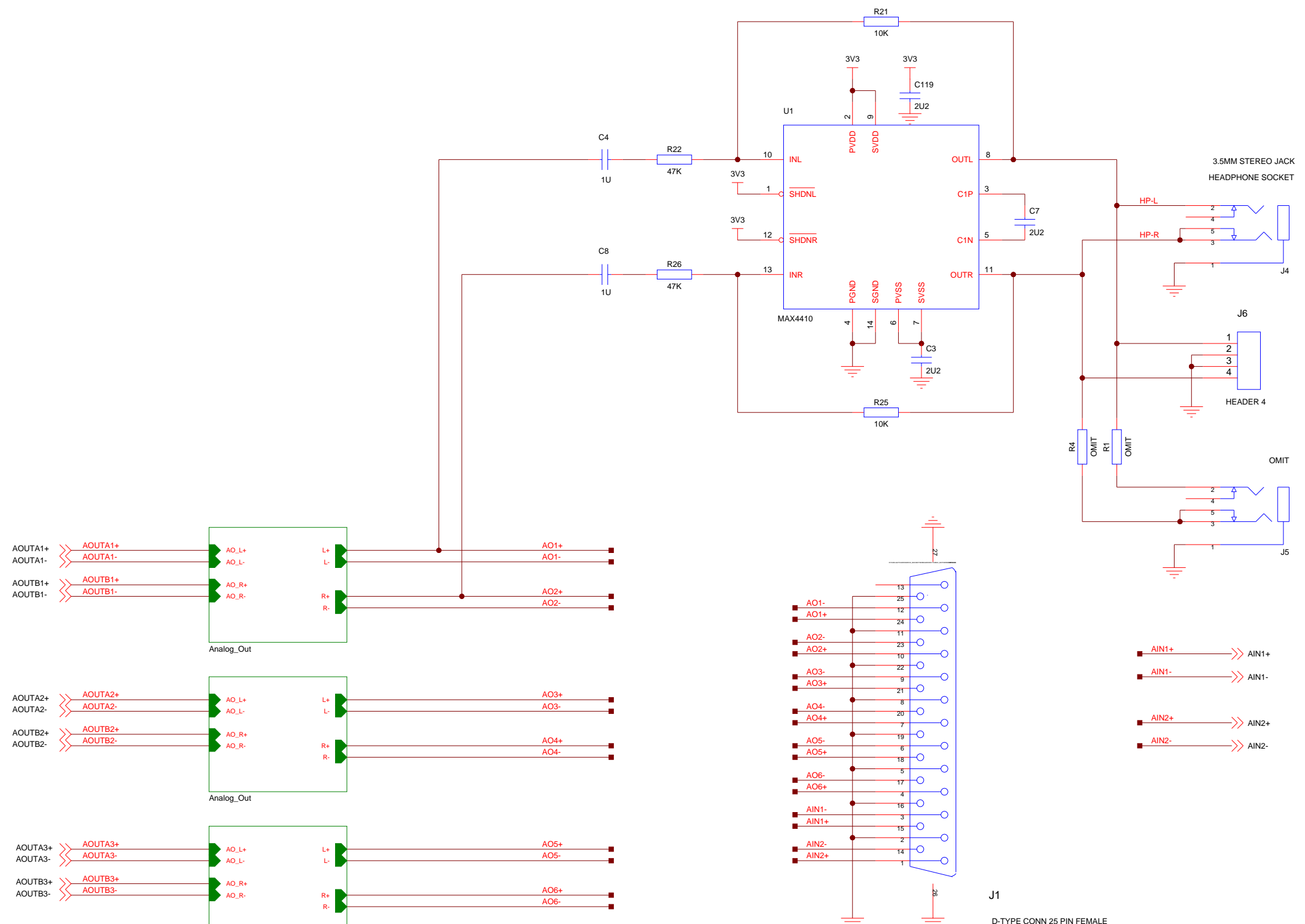

Fairlight AU Pty. Ltd.
Unit 3, 15 Rodborough Rd
Frenchs Forest, NSW, 2086, Australia

TITLE
SX-12V Analog Out

SIZE A3 DWG NO B10X101B REV B

SCALE SHEET 1 of 10 4-28-2011_18:25

DRAWN BY RLS

6

5

4



3

2

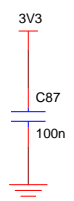
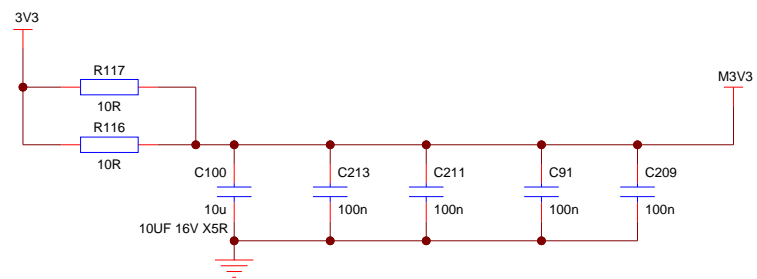
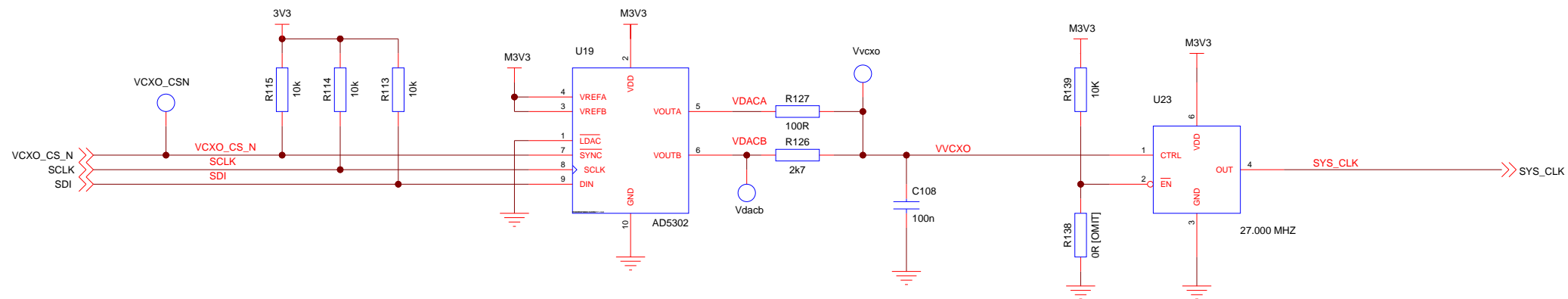
1

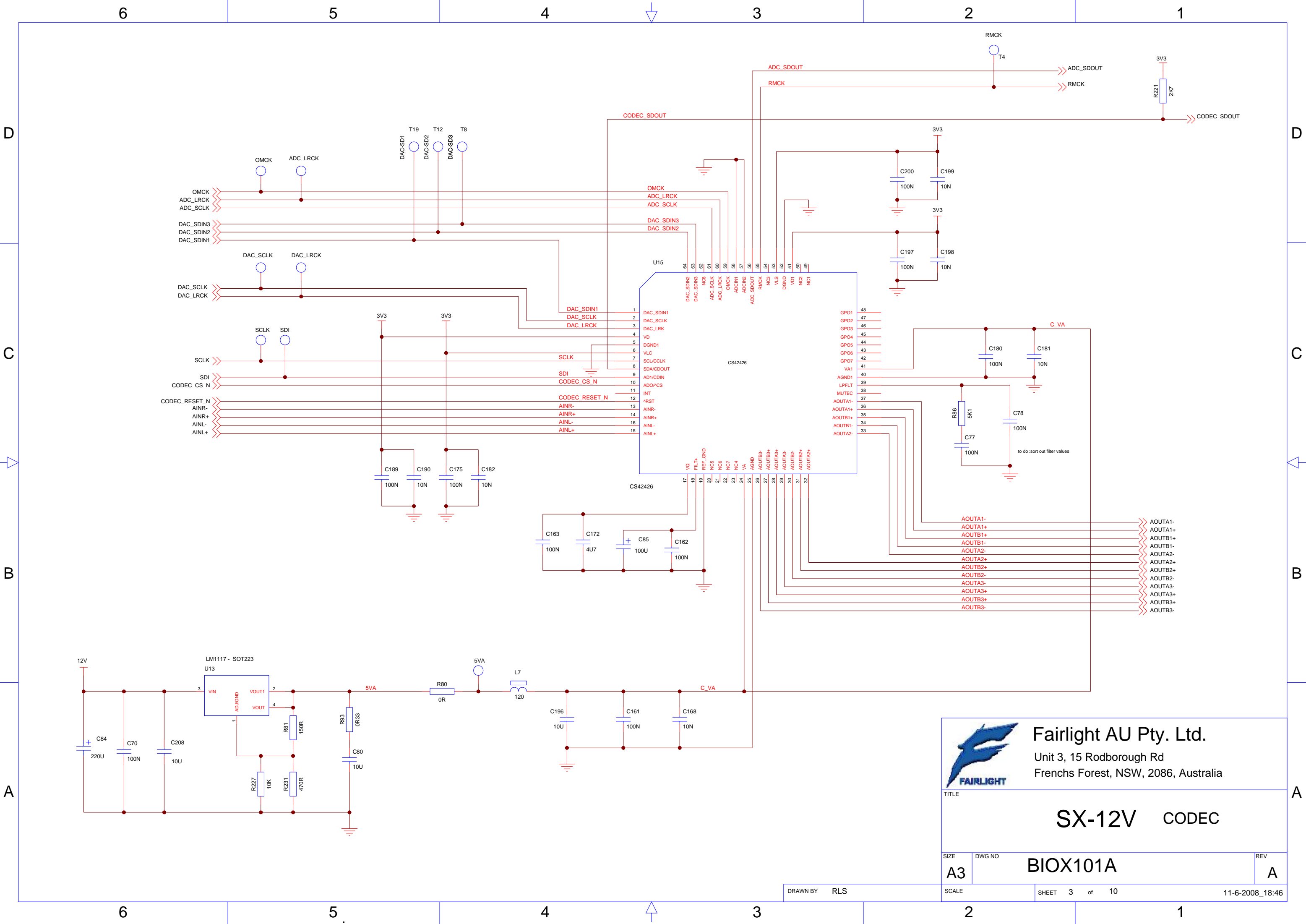

 Fairlight AU Pty. Ltd. Unit 3, 15 Rodborough Rd Frenchs Forest, NSW, 2086, Australia	
TITLE	
<h1>SX-12V VCXO</h1>	
SIZE	DWG NO
A3	BIOX101A
SCALE	REV
	A
DRAWN BY RLS	
SHEET 2 of 10	
7-30-2009_16:29	





Fairlight AU Pty. Ltd.
 Unit 3, 15 Rodborough Rd
 Frenchs Forest, NSW, 2086, Australia

TITLE
SX-12V CODEC

SIZE A3	DWG NO BIOX101A	REV A
SCALE	SHEET 3 of 10	11-6-2008_18:46

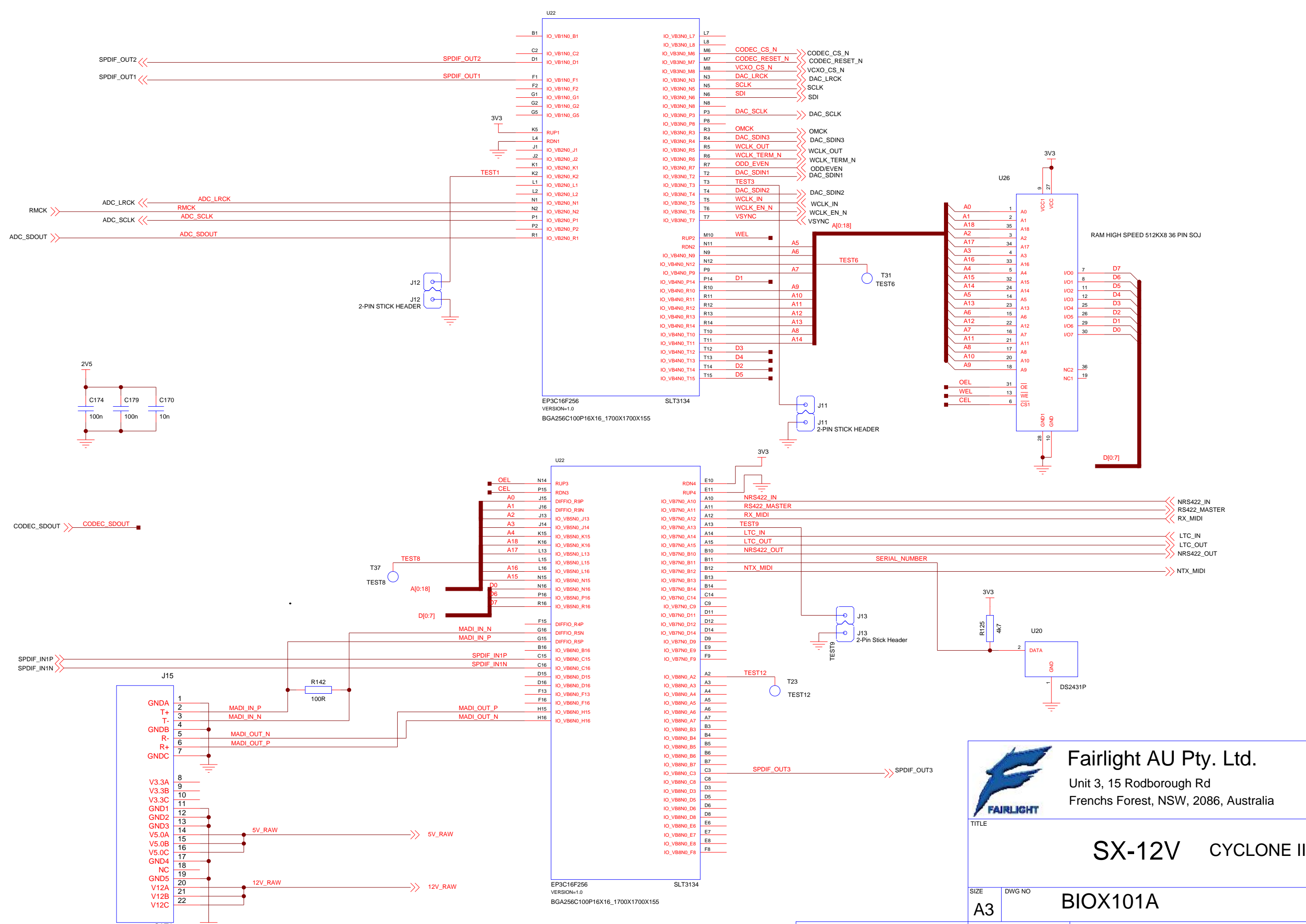
DRAWN BY RLS



Fairlight AU Pty. Ltd.
 Unit 3, 15 Rodborough Rd
 Frenchs Forest, NSW, 2086, Australia

SX-12V CYCLONE III

TITLE

SIZE **A3** DWG NO **BIOX101A** REV **A**

DRAWN BY **RLS** SCALE SHEET **4** of **10** 11-13-2008_15:14

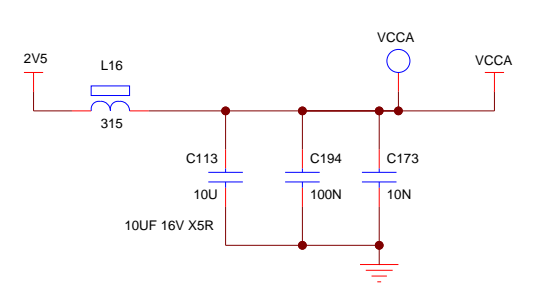
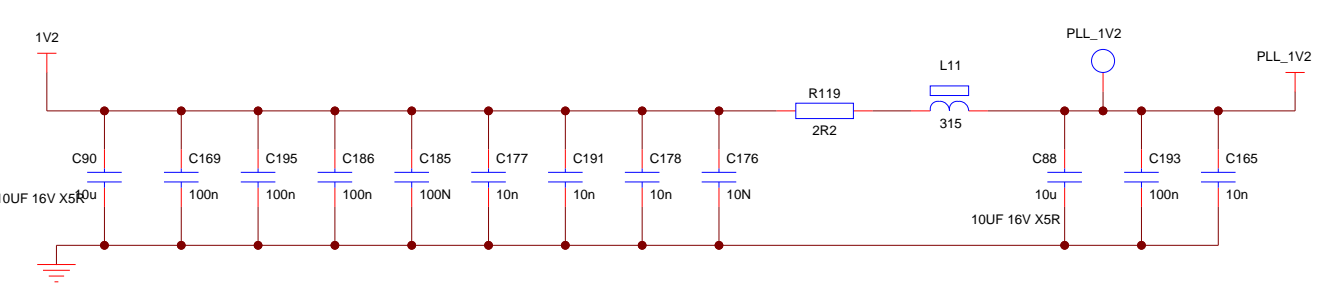
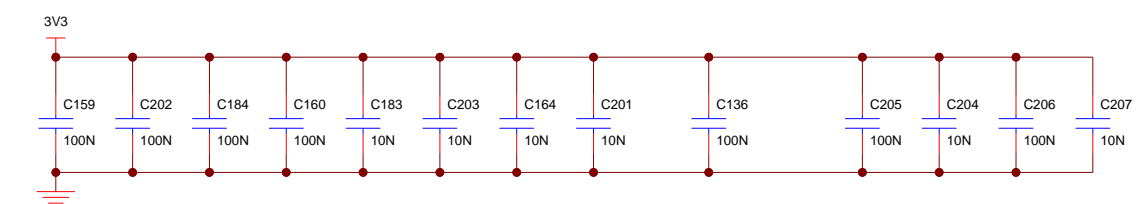
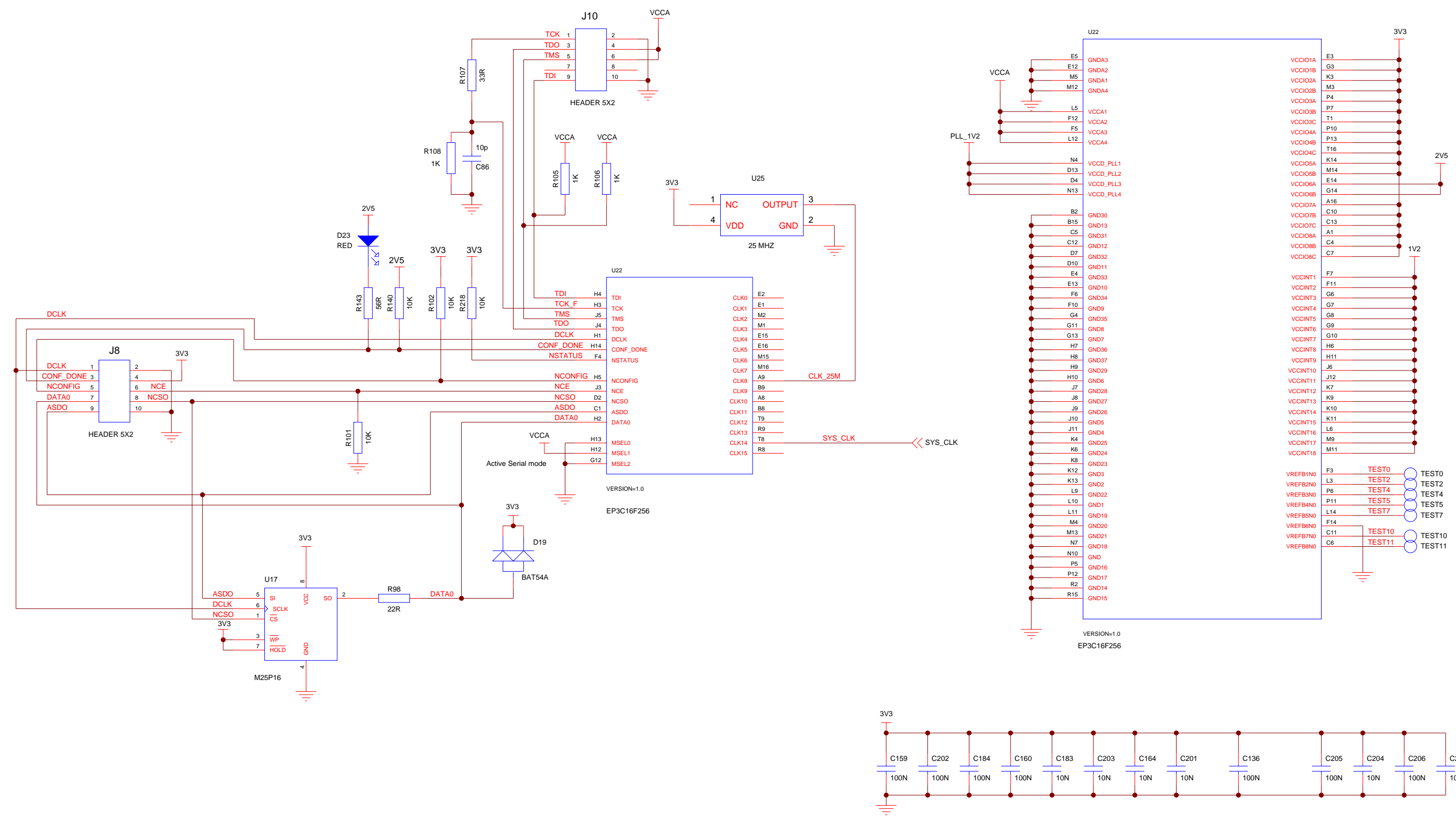



Fairlight AU Pty. Ltd.
 Unit 3, 15 Rodborough Rd
 Frenchs Forest, NSW, 2086, Australia

TITLE		SX-12V CYCLONE POWER	
SIZE	DWG NO	REV	A
A3	BIOX101A		
SCALE	SHEET 5 of 10	4-28-2011_18:25	

DRAWN BY RLS

6

5

4

3

2

1

D

D

C



C

B

B

A

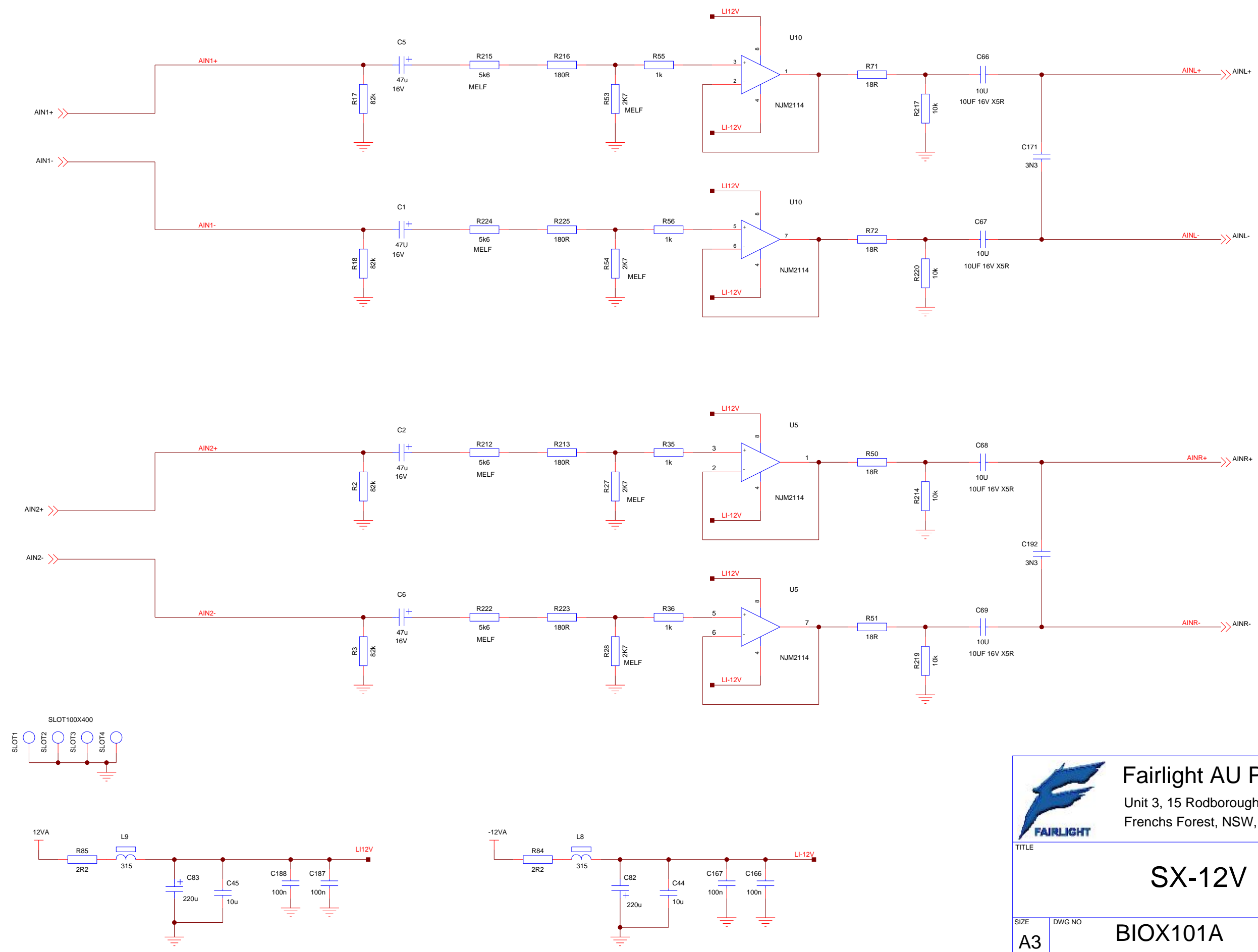
A

Fairlight AU Pty. Ltd.
 Unit 3, 15 Rodborough Rd
 Frenchs Forest, NSW, 2086, Australia

TITLE
SX-12V ANALOG IN

SIZE A3	DWG NO BIOX101A	REV A
SCALE	SHEET 6 of 10	4-28-2011_18:25

DRAWN BY RLS

6 5 4 3 2 1

D

C

B

A

D

C

B

A

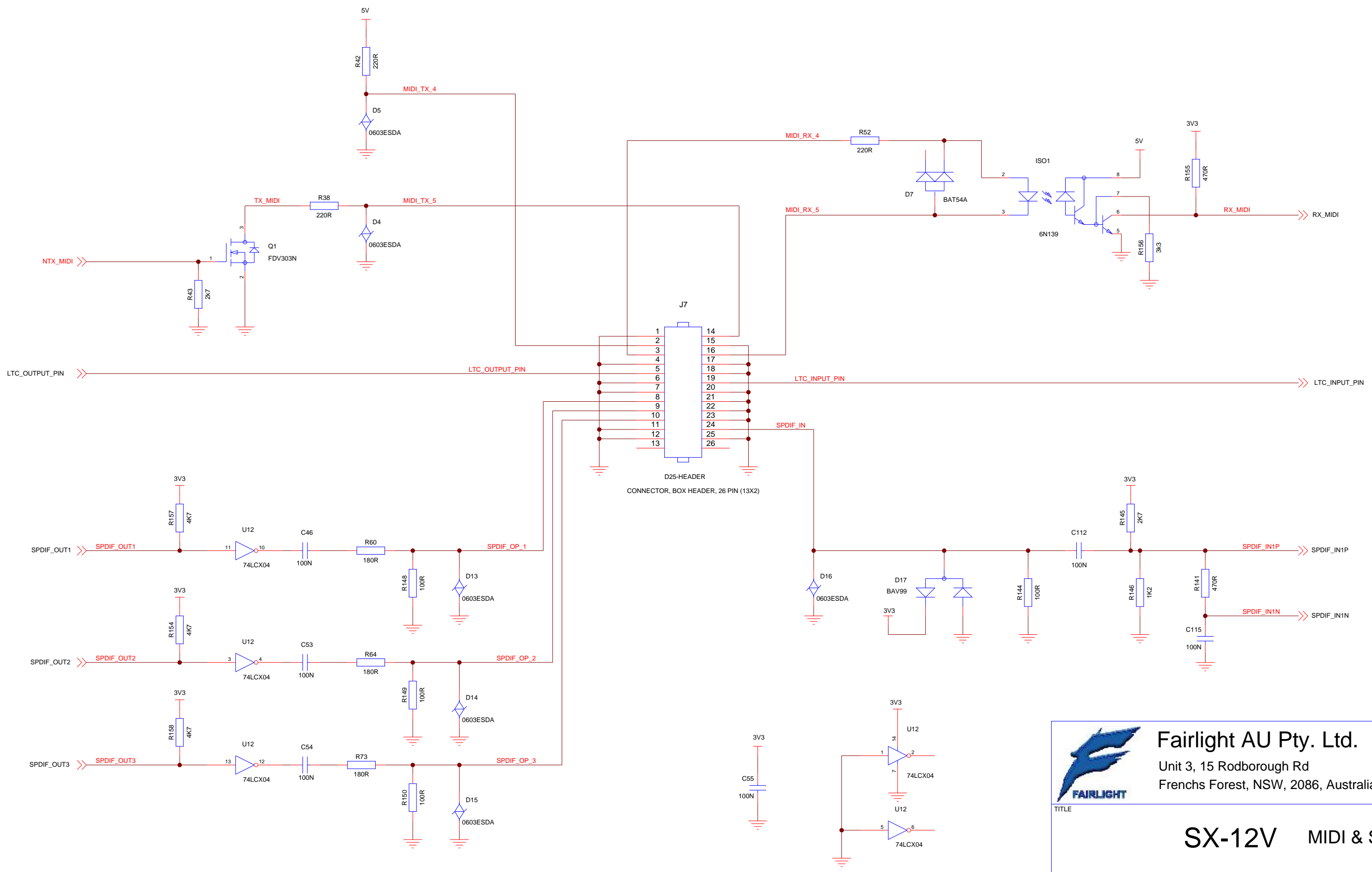



Fairlight AU Pty. Ltd.
 Unit 3, 15 Rodborough Rd
 Frenchs Forest, NSW, 2086, Australia

SX-12V MIDI & S/PDIF

SIZE	DWG NO	REV
A3	BIOX101A	A
SCALE	SHEET 7 of 10	11-6-2008_14:09

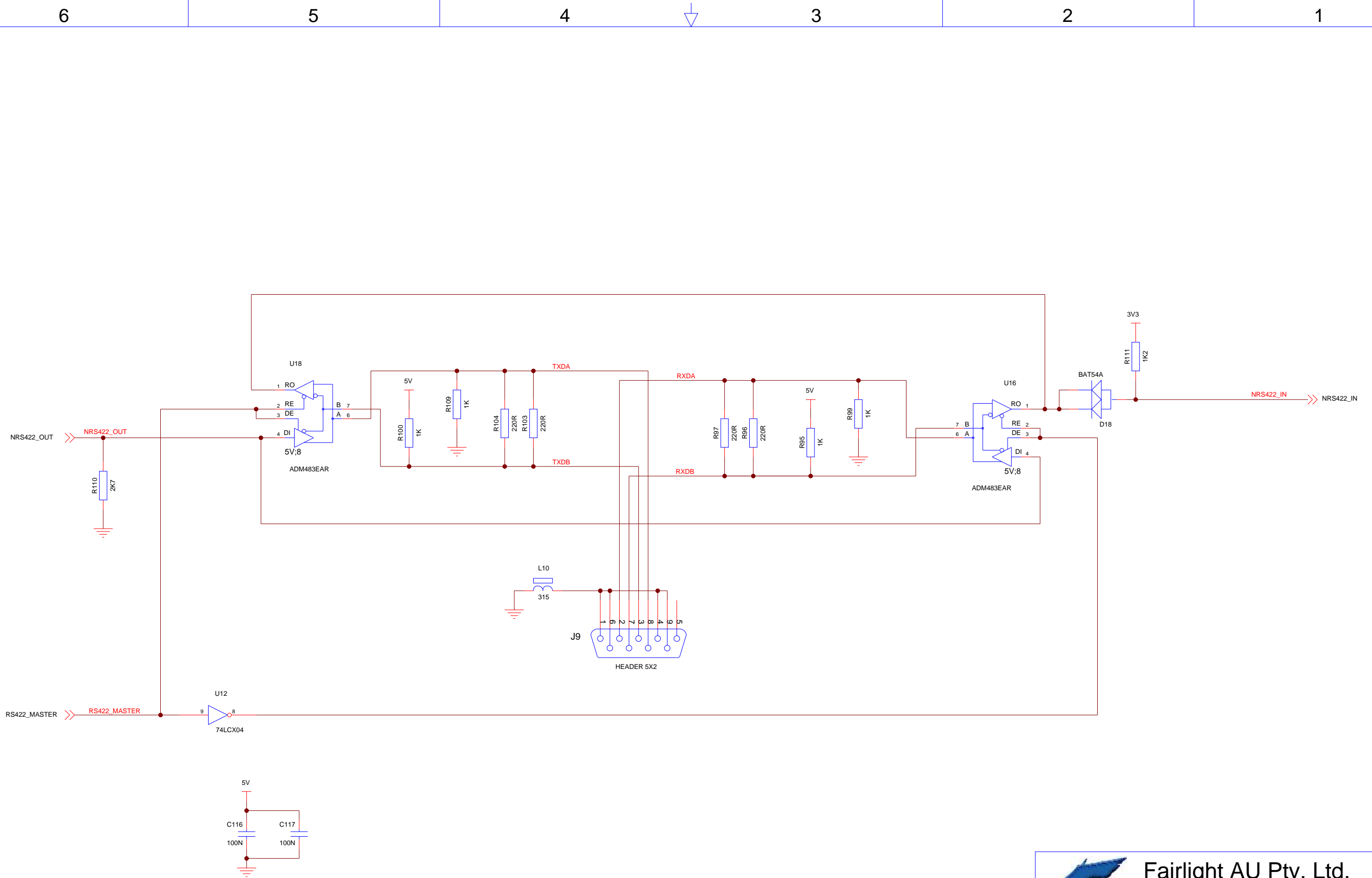
DRAWN BY RLS



 Fairlight AU Pty. Ltd. Unit 3, 15 Rodborough Rd Frenchs Forest, NSW, 2086, Australia	
SX-12V 9-PIN	
TITLE	REV
A3	BIOX101A
DRAWN BY RLS	SCALE
SHEET 8 of 10	7-30-2009_16:29

6 5 4 3 2 1

D

C

B

A

D

C

B

A

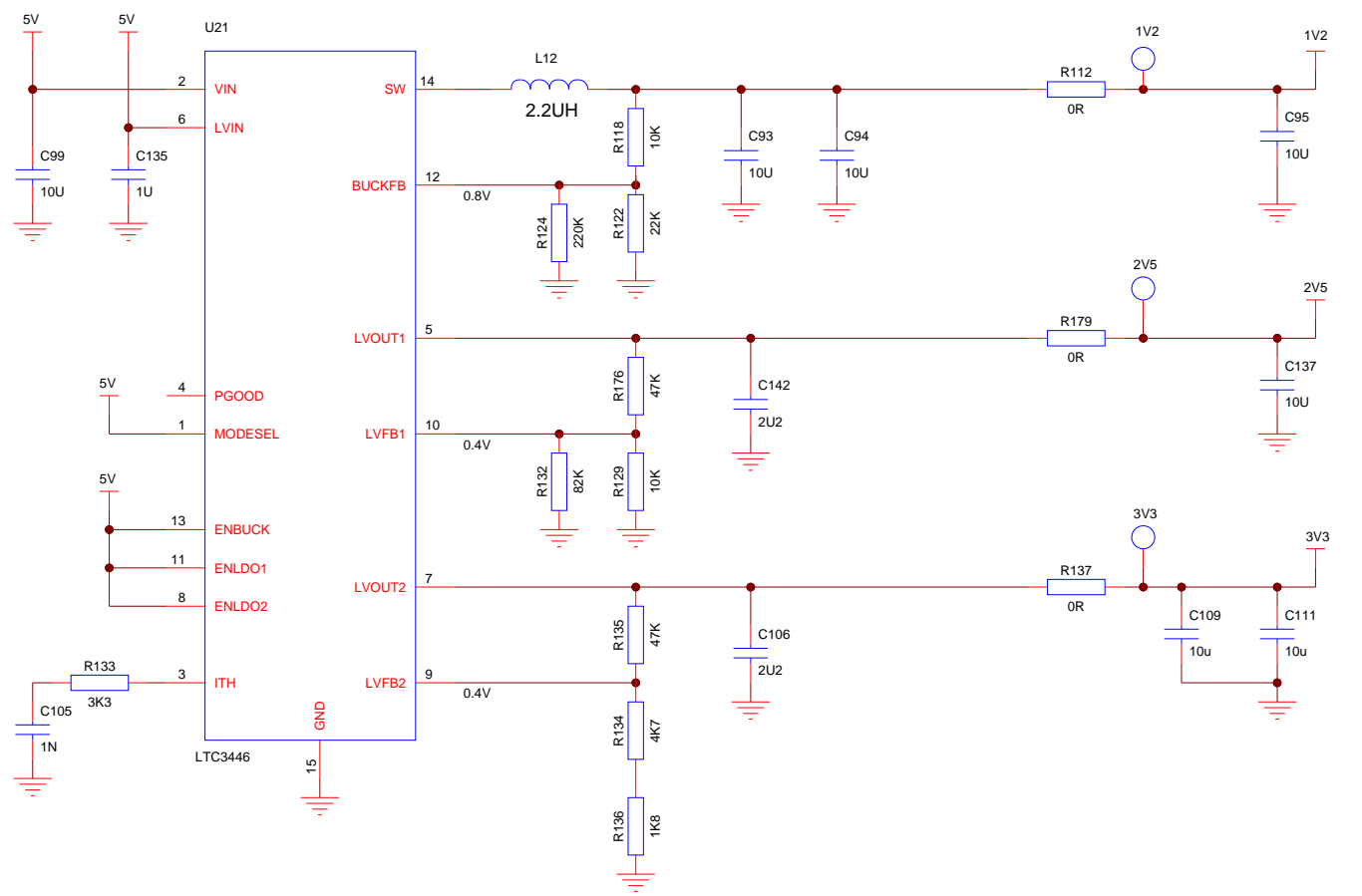
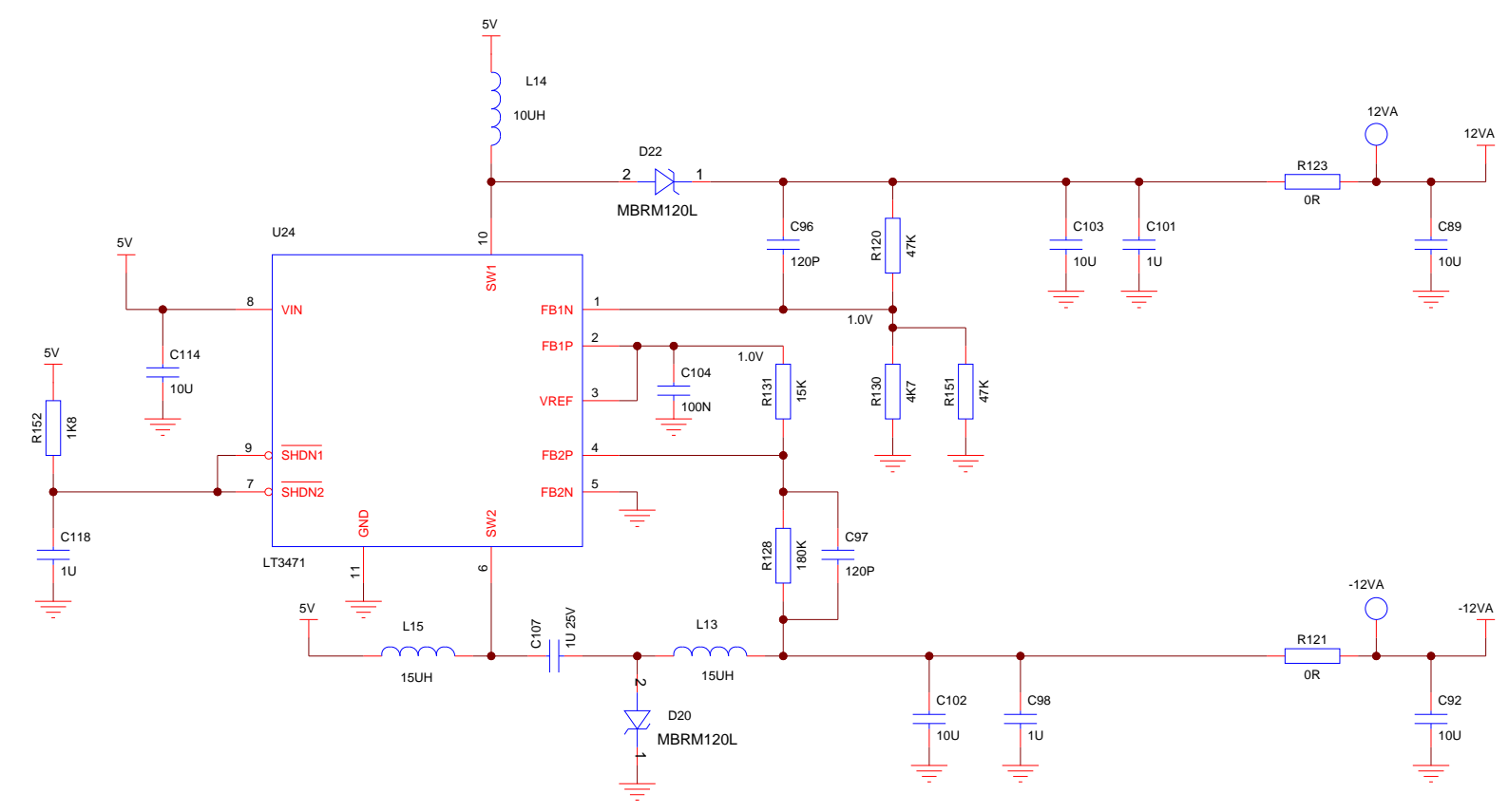
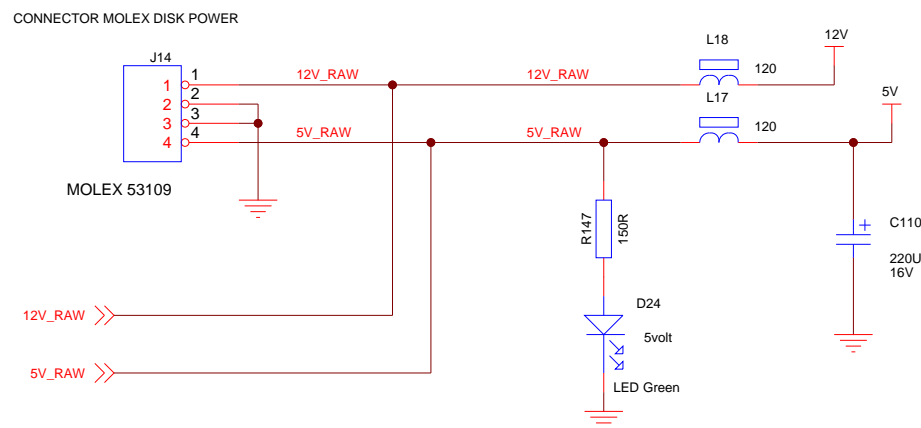
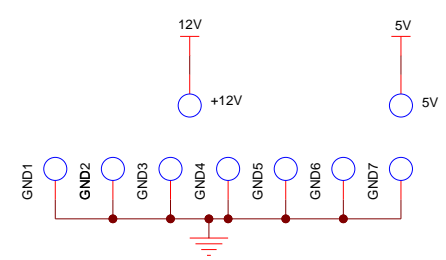



 **Fairlight AU Pty. Ltd.**
 Unit 3, 15 Rodborough Rd
 Frenchs Forest, NSW, 2086, Australia

TITLE
SX-12V POWER

SIZE	DWG NO	REV
A3	BIOX101A	A

DRAWN BY RLS SCALE SHEET 9 of 10 12-9-2008_11:53

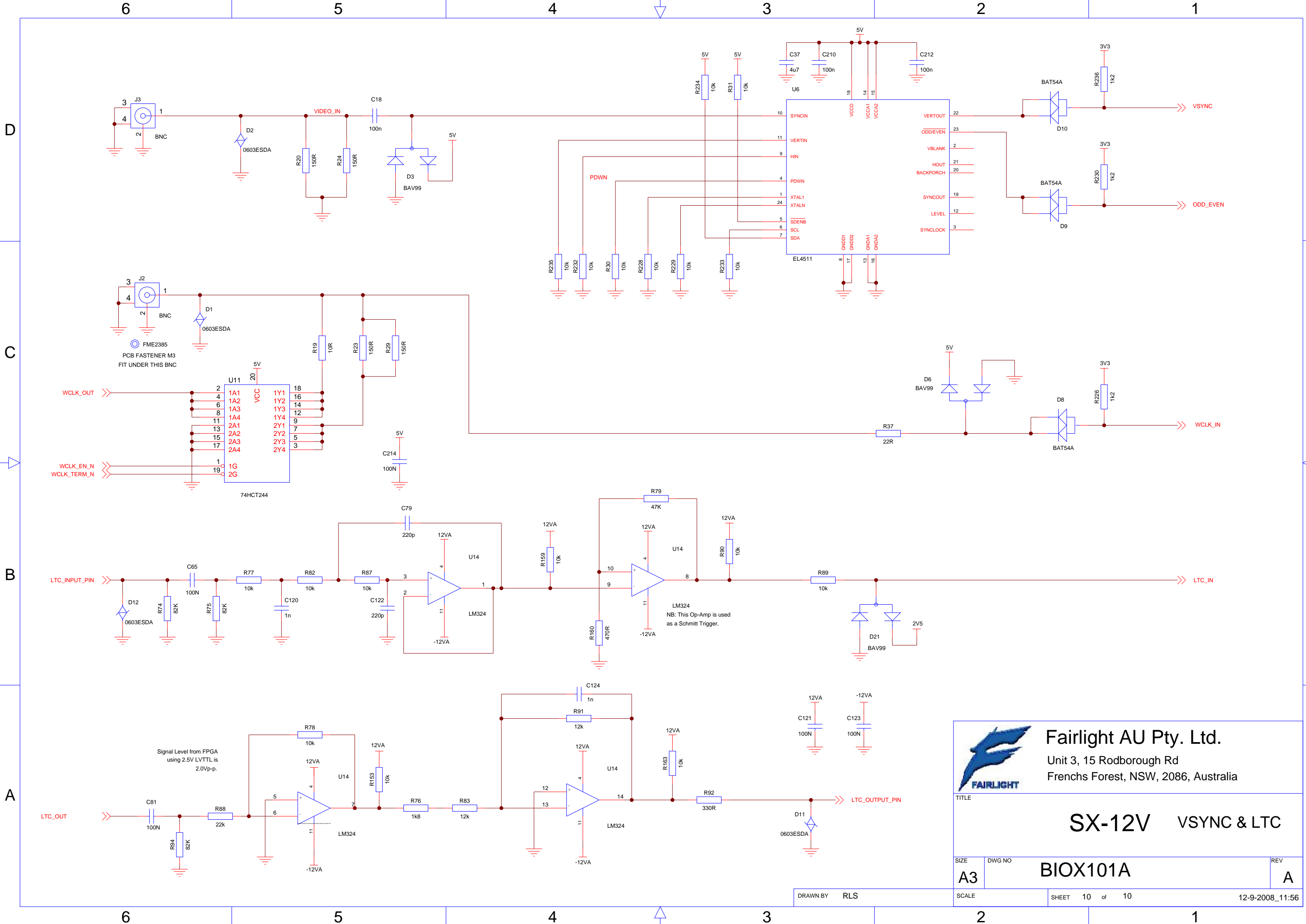
6 5 4 3 2 1

Fairlight AU Pty. Ltd.
 Unit 3, 15 Rodborough Rd
 Frenchs Forest, NSW, 2086, Australia

TITLE
SX-12V VSYNC & LTC

SIZE DWG NO REV
A3 BIOX101A A

SCALE SHEET 10 of 10 12-9-2008_11:56

DRAWN BY RLS

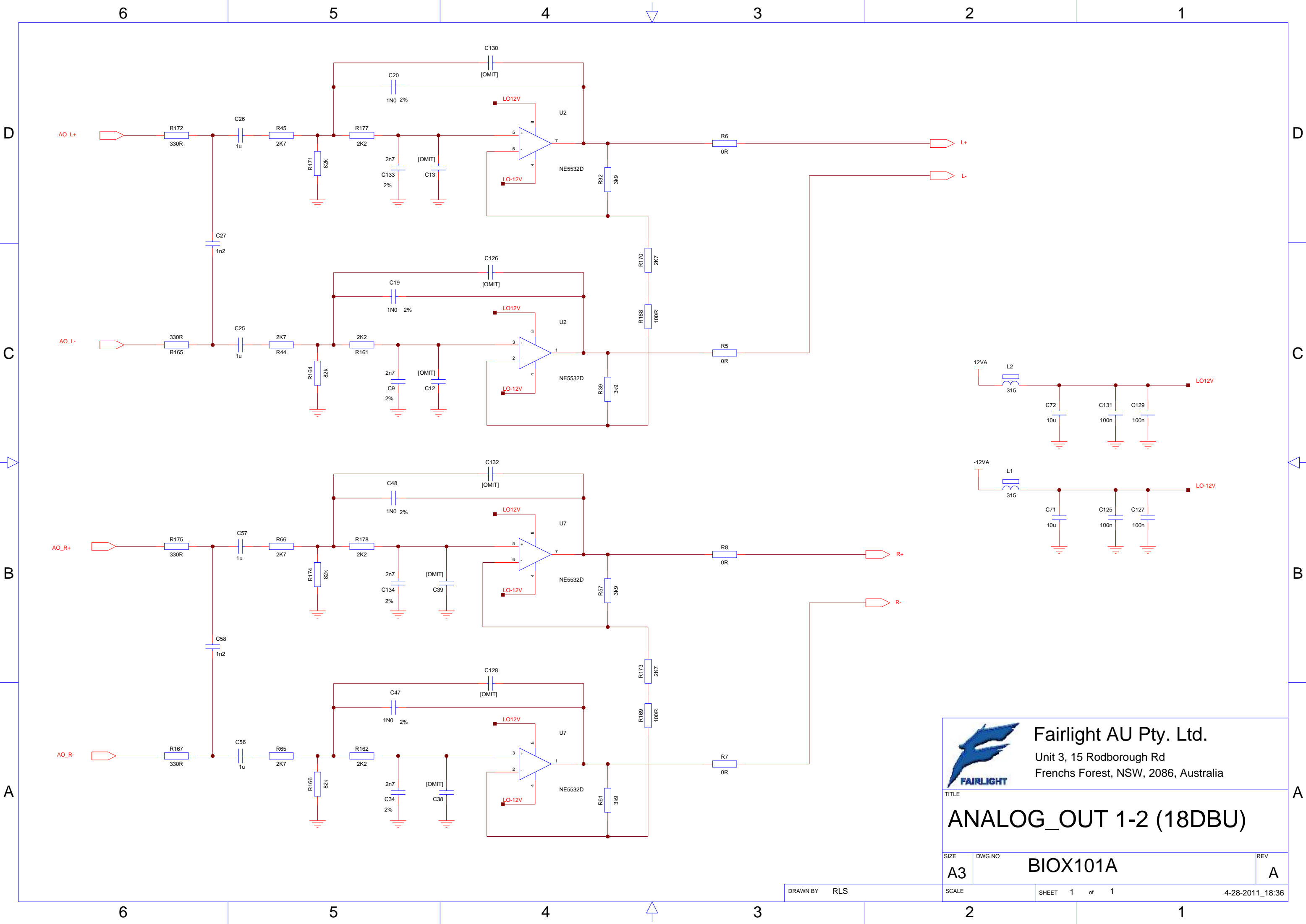



Fairlight AU Pty. Ltd.
 Unit 3, 15 Rodborough Rd
 Frenchs Forest, NSW, 2086, Australia

TITLE
ANALOG_OUT 1-2 (18DBU)

SIZE	DWG NO	REV
A3	BIOX101A	A

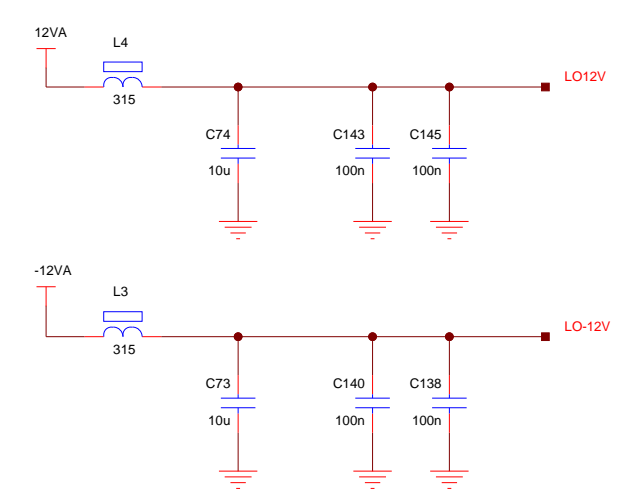
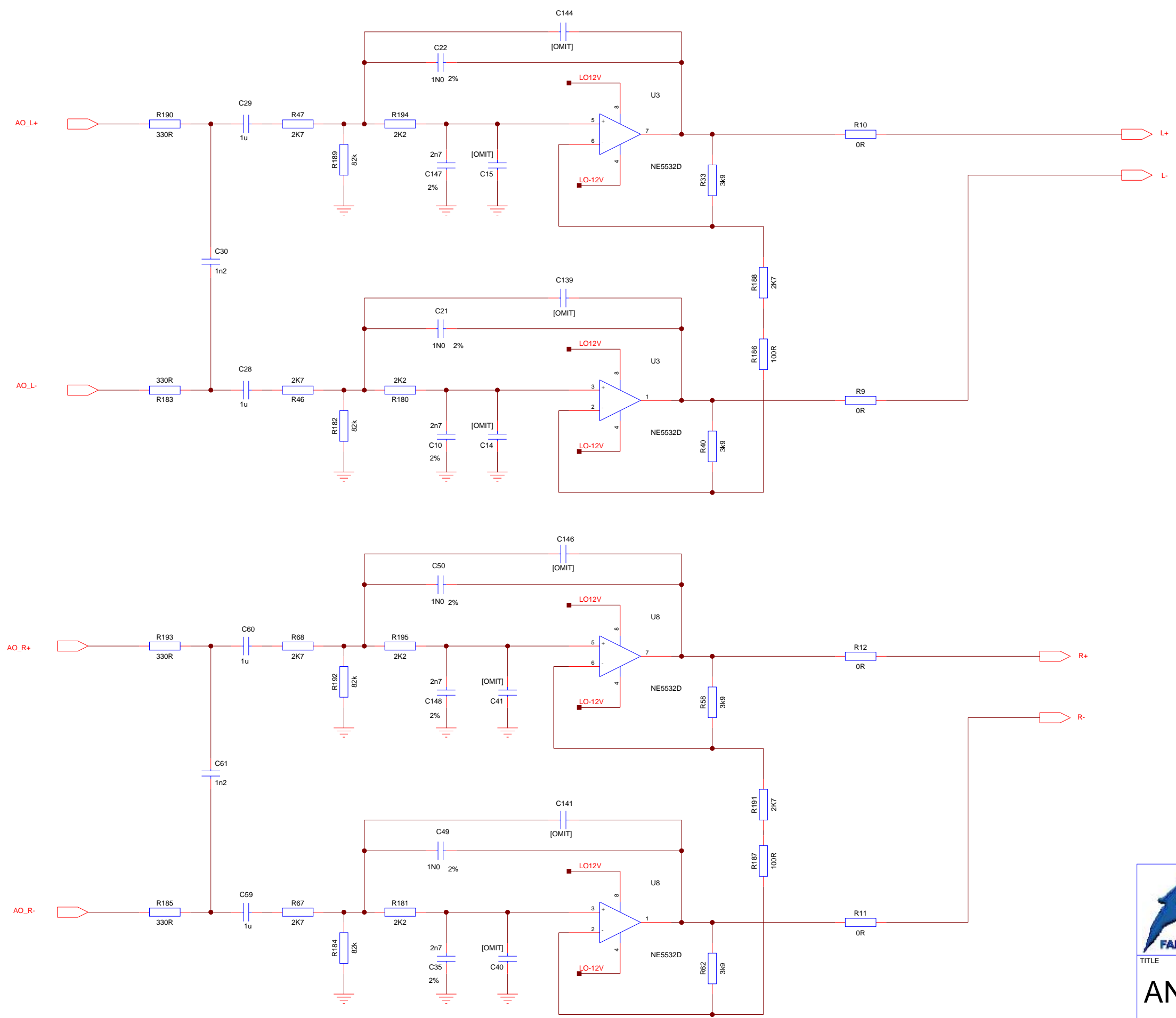
DRAWN BY RLS SCALE SHEET 1 of 1 4-28-2011_18:36



Fairlight AU Pty. Ltd.
 Unit 3, 15 Rodborough Rd
 Frenchs Forest, NSW, 2086, Australia

TITLE		
ANALOG_OUT 3-4 (18DBU)		
SIZE	DWG NO	REV
A3	BIOX101A	A
SCALE	SHEET 1 of 1	
4-28-2011_18:36		

DRAWN BY RLS

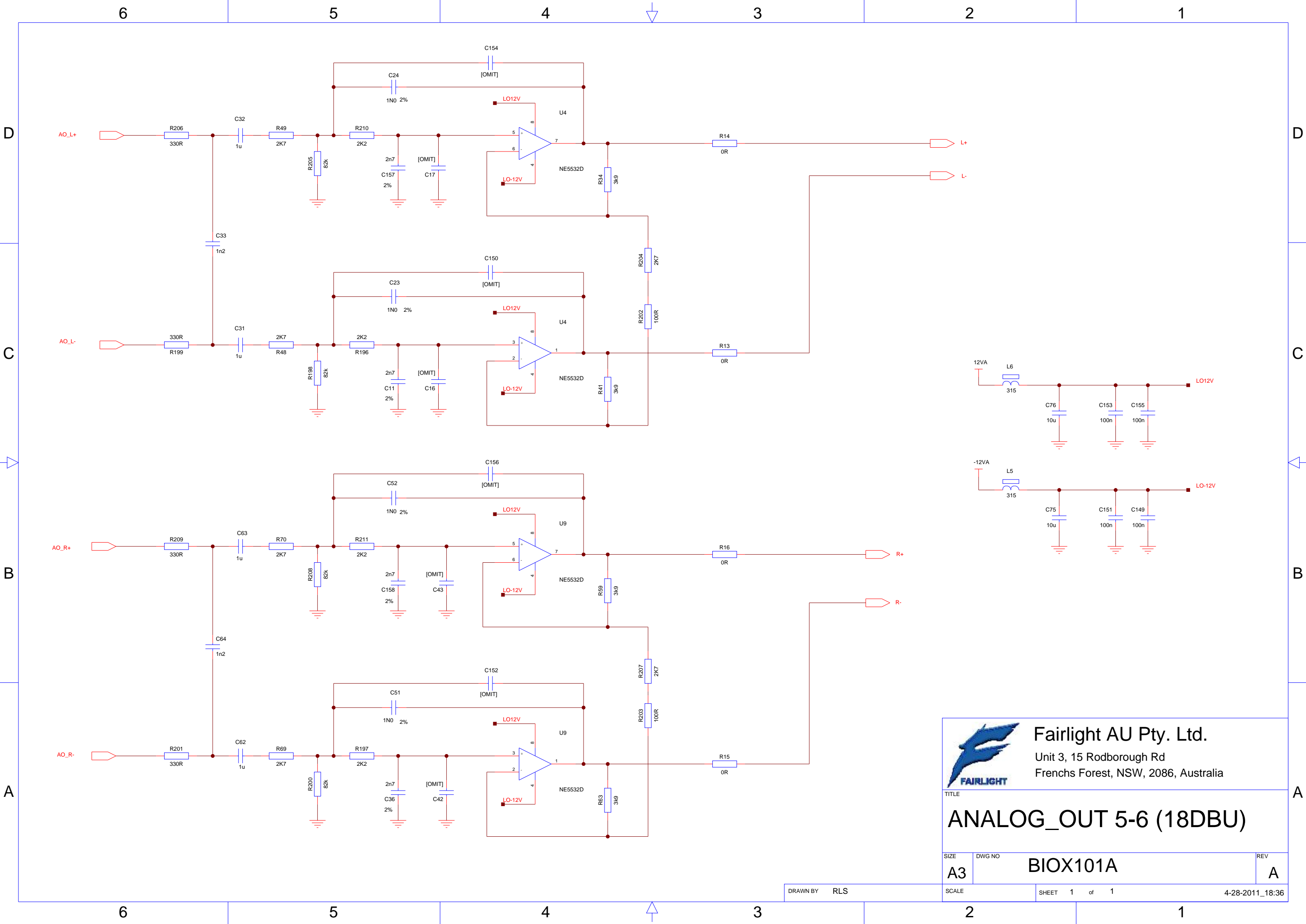

Fairlight AU Pty. Ltd.

Unit 3, 15 Rodborough Rd
 Frenchs Forest, NSW, 2086, Australia

TITLE		
ANALOG_OUT 5-6 (18DBU)		
SIZE	DWG NO	REV
A3	BIOX101A	A
SCALE	SHEET 1 of 1	4-28-2011_18:36

DRAWN BY RLS